

Uninterruptible Power Supply-UPS

Online HF UPS

6KVA-20KVA

USER MANUAL

1. Brief introduction:	2
1.1 System and model description	2
1.2 Description of commonly used symbols	3
1.3 LCD display and function of buttons:	5
1.4 Display information	5
1.4 Product specification and performance	11
2. Installation	13
2.1 Unpacking and inspection	13
2.2 Input and output power cords and protective earth ground installation	14
2.3 Installation	14
2.4 Operating procedure for connecting the long backup time model UPS with the external battery	16
3. Operation and operating mode	17
3.1 Operation	17
3.1.1. Turn on the UPS with utility power supplied (in Line mode/AC mode)	17
3.1.2. Turn on the UPS with no utility power supplied (in Battery mode)	17
3.1.3. Turn off the UPS with no utility power supplied (in Battery mode)	18
3.2 Operating mode	19
3.2.1. Utility power mode	19
3.2.2. Battery mode	19
3.2.3. Bypass mode	20
3.2.4. Abnormality mode	21
3.2.5. Backup time for the standard model	21
3.2.6. Communication Port	22
4. Battery Maintenance	24
5. Notes for battery disposal and battery replacement	24
6. Trouble shooting instructions	25
6.1 Warning code and Fault code	25
6.2 Simple problem phenomena and solutions	27

1. Brief introduction:

1.1 System and model description

This Online Series is an uninterruptible power supply incorporating double-conversion technology. It provides perfect protection specifically for computer equipment, Communication Systems to computerized instruments.

Its true online double-conversion design eliminates all mains power disturbances. A rectifier converts the alternating current from the utility power to direct current. This direct current charges the batteries and powers the inverter. On the basis of this DC voltage, the inverter generates a pure sinusoidal AC voltage, which is constantly powering the loads.

Computers and Peripherals are thus powered entirely by the UPS. In the event of power failure, the maintenance-free batteries power the inverter.

This manual is applicable to the following models:

- 1) The 6KS is a standard model with inbuilt battery, hereinafter called 6KS;
- 2) The 6KL is a long backup time model, which is able to connect with the external battery bank, hereinafter called 6KS;
- 3) The 10KS is a standard model with inbuilt battery, hereinafter called 10KS;
- 4) The 10KL is a long backup time model, which is able to connect with the external battery bank
- 5) The 310K is a three-phase input and single-phase output long backup time model, which is able to connect with the external battery bank.
- 6) The 315K is a three-phase input and single-phase output long backup time model, which is able to connect with the external battery bank. Hereinafter called three-phase 15KL.7) The 320KL is a three-phase input and single-phase output long backup time model, which is able to connect with the external battery bank.

1.2 Description of commonly used symbols

The following symbols will be used in this manual and may appear during the course of your practical applications. Therefore, all users should be familiar with them and understand their meanings

Appearance

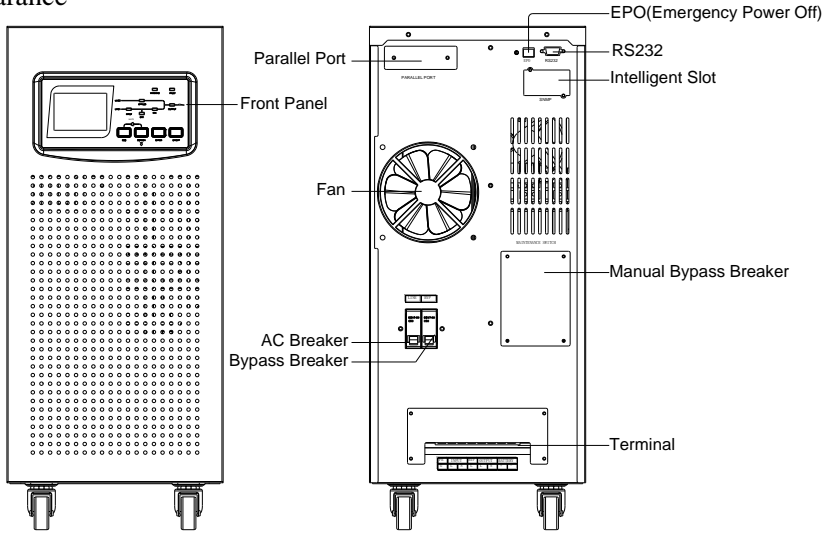

(Front and Back View of 6KVA single phase)

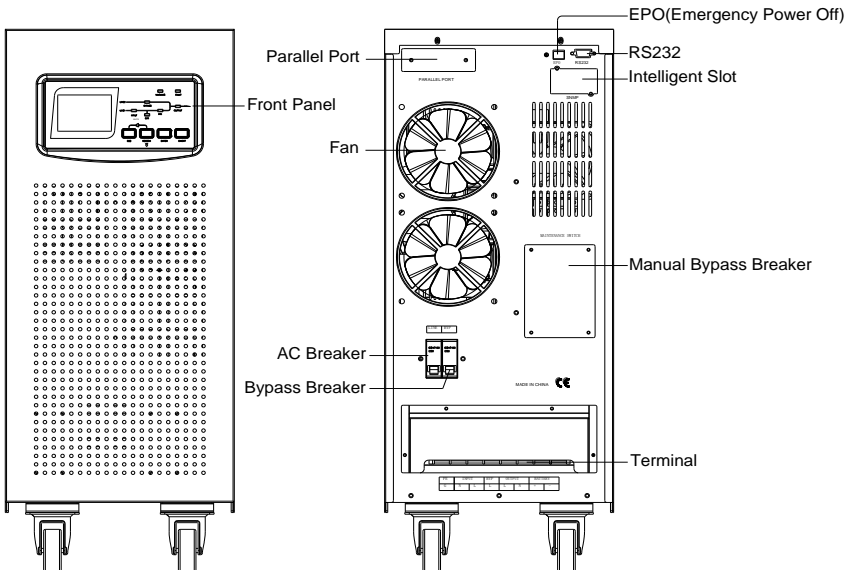

(Front and Back View of 10KVA single phase)

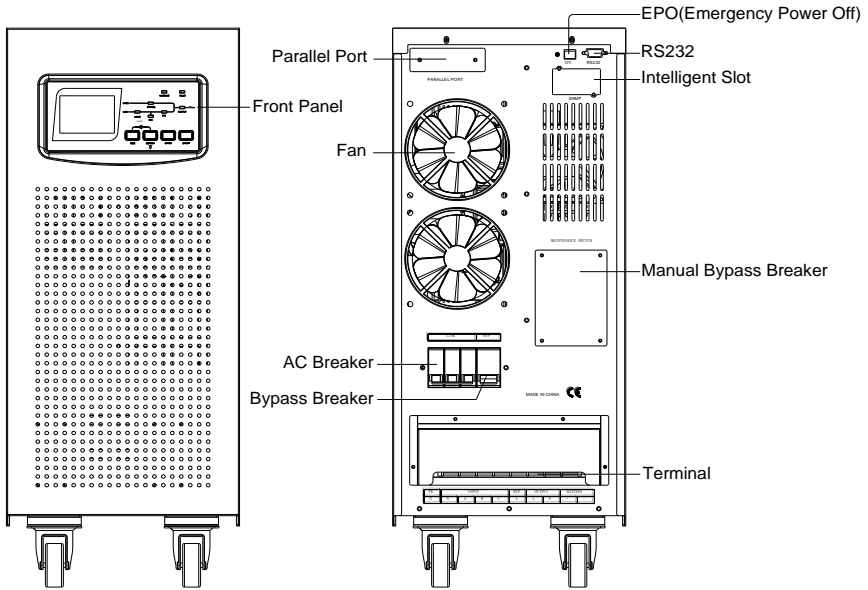

(Front and Back View of 10-15KVA 3/1 phase)

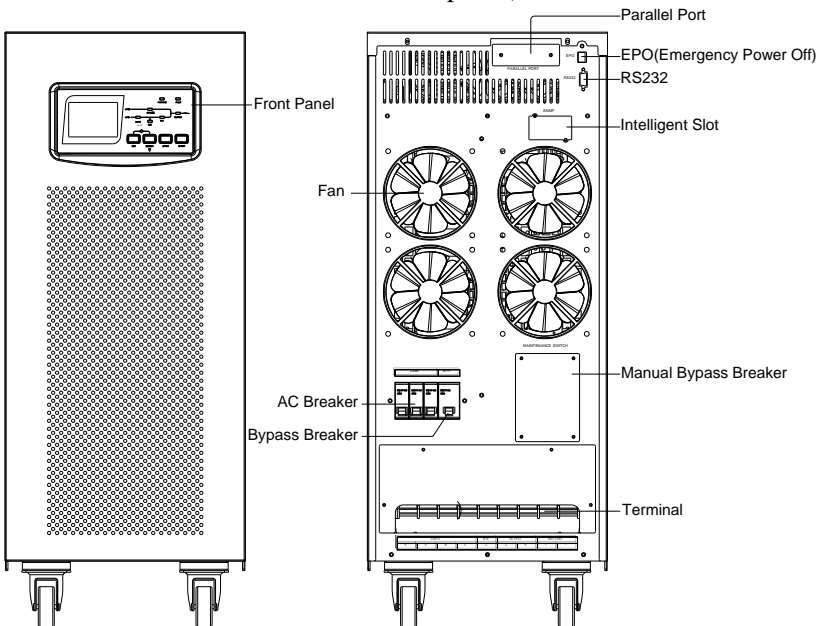

(Front and Back View of 20KVA 3/1phase)

1.3 LCD display and function of buttons:

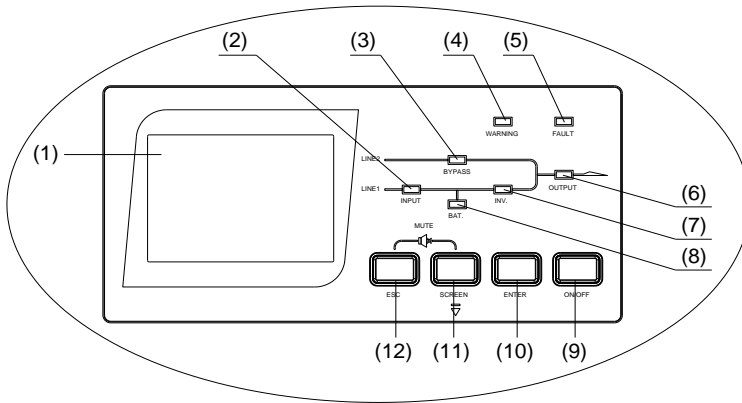

1 (1) LCD display screen. Display the working parameter and status of the UPS.

(2) Main power input indicator (green). It will light when main power is normal.

(3) Bypass input indicator (green). It will light when UPS is in bypass model.

(4) Warning indicator(red). It will light when the system gives warning.

(5) Error alarm indicator (red). It will light with alarm when UPS has fault.

(6) Output indicator(green).It will light when the output is available.

(7) Inverter output indicator (green). It will light when the Inverter is working.

(8) —Battery is working (yellow). It will light when battery supply power to UPS.
“Screen” is to view and choose the functions or items.

(9) —“—ON/OFF”. Press it longer than 1 second, the UPS will start or turn off.

(10) "Enter". This button is to confirm where the cursor points or the parameter setting.

(11)"Screen". This button is to choose the next menu.

(12) "ESC". This menu is to return to the previous menu.

1.4 Display information

1) Turn on the A/C input switch and touch “ON/OFF” button, LCD will display as below:.

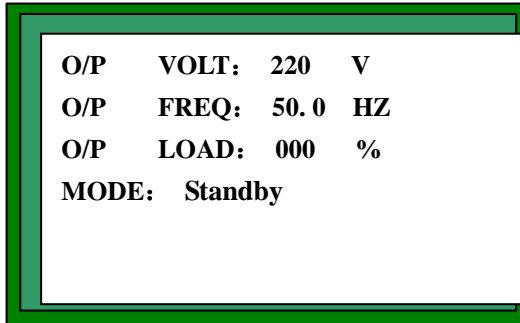

2) Press the ON/OFF button for over 2 second, UPS will enter starting up process

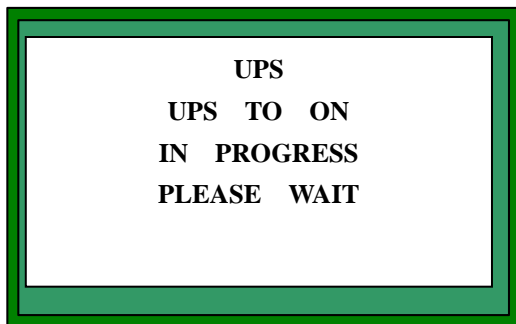

3)10 seconds later, UPS will transfer to Inverter output, the “sleep” mode become “main power mode”

OP VOLT:	220	V
FREQ:	0 0 . 0	HZ
LOAD:	000	%
CURRENT:	000	A

4) Press "Enter" to enter "Function Menu"

STATUS
MODEL INFO
EVENT LOG
Version: Ver:HV 7.6***

5) Select "**** DATA" and press "Enter" to check parameters

OUTPUT DATA
INPUT DATA
BATTERY DATA
DC LINK DATA

6) Select “OUTPUT DATA” and press “enter” to check the parameter of output.

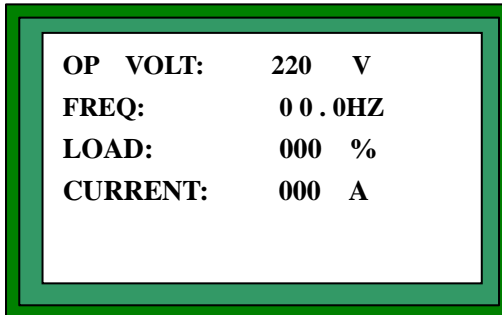

OP VOLT: 220 V
FREQ: 00.0HZ
LOAD: 000 %
CURRENT: 000 A

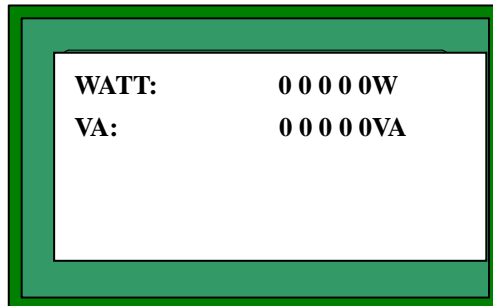

WATT: 00000W
VA: 00000VA

7) Press “ESC”, the window will be back to last page, select “MODEL INFO” and press “Enter”

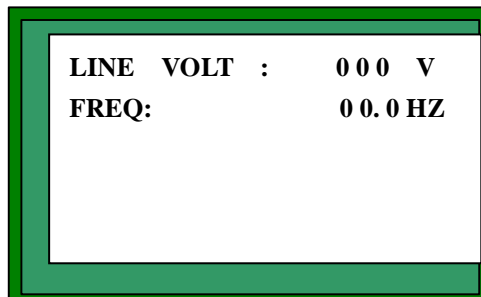

LINE VOLT : 000 V
FREQ: 00.0 HZ

8) Or you may select “BATTERY DATA” and press “Enter” to check the battery status.

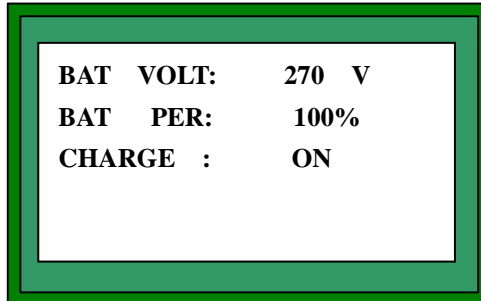

A screenshot of a menu titled "BATTERY DATA" displayed on a screen. The menu is enclosed in a green border. It contains three lines of text: "BAT VOLT: 270 V", "BAT PER: 100%", and "CHARGE : ON".

BAT VOLT:	270 V
BAT PER:	100%
CHARGE :	ON

9) Or you may check the UPS inner DC Bus voltage under “DC DATA”

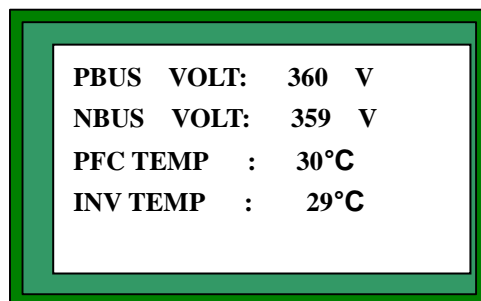

A screenshot of a menu titled "DC DATA" displayed on a screen. The menu is enclosed in a green border. It contains four lines of text: "PBUS VOLT: 360 V", "NBUS VOLT: 359 V", "PFC TEMP : 30°C", and "INV TEMP : 29°C".

PBUS VOLT:	360 V
NBUS VOLT:	359 V
PFC TEMP :	30°C
INV TEMP :	29°C

10) Press “ESC” to return to the last step, press “INPUT DATA” and “Enter” to check the UPS information.

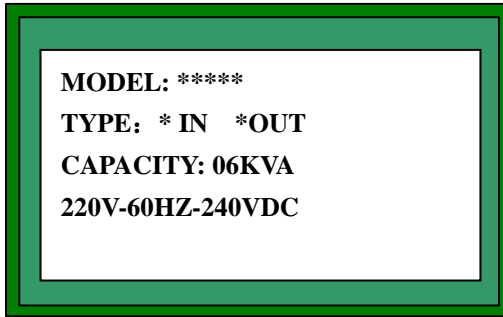

11) Select "EVENT LOG" MENU, press "ENTER" button

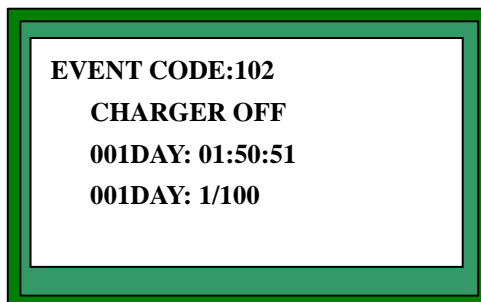
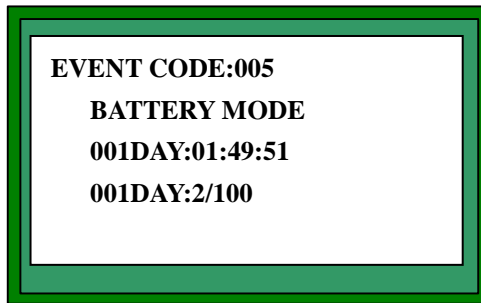

Explanation: a) **Regarding time.** UPS will overlay to calculate the running time."For example:"001DAY:01:50:51" It means "Charger OFF" happened at

the moment after UPS running 1day,1hour 50mins and 51seconds.

b)Regarding events:UPS will record maximum 100 events and update automatically when new events happens. “1/100” is the latest event, and then the 2/100,3/100,,till 100/100;

And when new event happens, new event become the 1/100 and previous 2/100, and the previous 100/100 will be erased.

12) Press the “ON/OFF” longer than 1 second, the UPS will shut off. LCD will display as below:

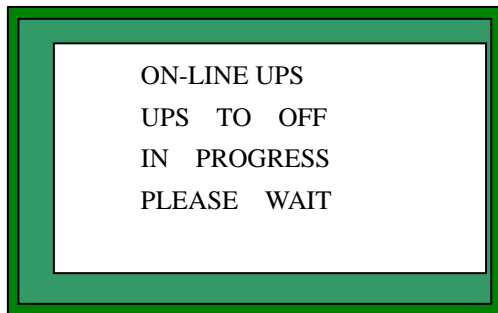

1.4 Product specification and performance

- General specification

Power rating	Model	Frequency (Hz)	Input		Battery
			Voltage	Current	Voltage
6kVA/4.8kW	6KS	50/60	(176-276) Or (80-150)Vac	31A max.	120/192/240 VDC
6kVA/4.8kW	6KL	50/60	(176-276) Or (80-150)Vac	31A max.	120/192/240 VDC
6kVA/4.8/5.4kW	6KS	50/60	(176-276) Or (80-150)Vac	31A max.	192/240VDC
6kVA/4.8/5.4kW	6KL	50/60	(176-276) Or (80-150)Vac	31A max.	192/240VDC
10kVA/8/9kW	10KS	50/60	(176-276) Or (80-150)Vac	50A max.	192/240VDC
10kVA/8/9kW	10KL	50/60	(176-276) Or (80-150)Vac	50A max.	192/240VDC
10kVA/8/9kW	3-phase10KS	50/60	(304-478)Or 138-260Vac	50A max.	192/240VDC
10kVA/8/9kW	3-phase10KL	50/60	(304-478)Or 138-260Vac	50A max.	192/240VDC
15kVA/12/13.5k W	3-phase15KL	50/60	(304-478)Vac	75A max.	192/240VDC
20kVA/16/18kW	3-phase20KL	50/60	(304-478)Vac	100A max.	192/240VDC
Model	Battery Current	Output		Unit Dimensions (W×L×H(mm))	Net Weight (kg)
		Voltage	Current		
CP06S	48A max	220VAC	23A	250*465*510	45
CP06L	48A max	220VAC	23A	230*510*385	20
CPP06S	30A max,	220VAC	27A	260 x582 x642	63
CPP06L	30A max,	220VAC	27A	260 x582 x642	27
CPP10S	50A max.	220VAC	45A	260 x582 x642	66
CPP10L	50A max.	220VAC	45A	260 x582 x642	29
CPP3110S	50A max.	220VAC	45A	260 x 582 x 642	73
CPP3110L	50A max.	220VAC	45A	260 x 582 x 642	36
CPP3115	75A max.	220VAC	68A	300 x 600 x 742	42
CPP3120	100A max.	220VAC	91A	300 x 600 x 742	42

● **Electrical performance**

Input			
Model	Voltage	Frequency	Power Factor
Single phase 6K	Single-phase	40Hz-70Hz	>0.99 (Full load)
Single phase 6K/10K	Single-phase	40Hz-70Hz	>0.99 (Full load)
Three-phase 10K/15K/ 20K	Three-phase	40Hz-70Hz	>0.95 (full load)

Output					
Voltage regulation	Power factor	Frequency tolerance	Distortion	Overload capacity	Current crest ratio
± 1%	0.8/0.9 lag	Synchronized 46~54Hz in Line mode(AC mode) ±0.1% of normal frequency in Battery mode.	THD<3% Full load (linear load)	105%~125% load transfers to bypass mode after 60s, 125%~150% load transfers to bypass after 30s.	3:1 maximum

● **Operating environment**

Temperature	Humidity	Altitude	Storage temperature
0°C~40°C	20%~90%	<1000m	-15°C~40°C

Note: if the UPS is installed or used in a place where the altitude is above than 1000m, the output power must be derated in use, please refer to the following :

Altitude (M)	1000	1500	2000	2500	3000	3500	4000	4500	5000
Derating power	100%	95%	91%	86%	82%	78%	74%	70%	67%

2. Installation

2.1 Unpacking and inspection

1) Unpack the packaging and check the package contents. The shipping package contains:

- A UPS
- A user manual
- A communication cable

2) Inspect the appearance of the UPS to see if there is any damage during transportation. Do not turn on the unit and notify the carrier and dealer immediately if there is any damage or lacking of some parts.

2.2 Input and output power cords and protective earth ground installation

1. Notes for installation

- 1) The UPS must be installed in a location with good ventilation, far away from water, inflammable gas and corrosive agents.
- 2) Ensure the air vents on the front and rear of the UPS are not blocked. Allow at least 0.5m of space on each side.
- 3) Condensation to water drops may occur if the UPS is unpacked in a very low temperature environment. In this case it is necessary to wait until the UPS is fully dried inside out before proceeding installation and use. Otherwise there are hazards of electric shock.

2.3 Installation

Installation and wiring must be performed in accordance with the local electric code and the following instructions by professional personnel.

For safety, please cut off the mains power switch before installation. The battery breaker also needs to be cut off if it is a long backup time model ("L" model).

- 1) Open the terminal block cover located on the rear panel of the UPS, please refer to the appearance diagram)
- 2) For 6K(L) UPS, it is recommended to select the UL1015 10AWG(6mm²) wire

or other insulated wire which complies with AWG Standard for the UPS input and output wirings.

- 3) For 10K(L)/3 phase 10KS UPS, it is recommended to select the UL1015 8AWG(10mm²) wire or other insulated wire which complies with AWG Standard for the UPS input and output wirings.
- 4) For 3 phase 15KS /3 phase 20KL UPS, it is recommended to select the UL1015 6AWG (25mm²) wire or other insulated wire which complies with AWG Standard for the UPS input and output wirings.

Note: Do not use the wall receptacle as the input power source for the UPS, as its rated current is less than the UPS's maximum input current. Otherwise the receptacle may be burned and destroyed.

- 5) Connect the input and output wires to the corresponding input and output terminals according to the following diagram.
- 6) Note: you must make sure that the input and output wires and the input and output terminals are connected tightly the protective earth ground wire refers to the wire connection between the equipment which consumes electric equipment and the ground wire. The wire diameter of protective earth ground wire should be at least as above mentioned for each model and green wire or green wire with yellow ribbon wire is used.
- 7) After having completed the installation, make sure the wiring is correct.
- 8) Please install the leak current protective breaker at the output power distribution panel of the UPS if necessary.
- 9) To connect the load with the UPS, please turn off all the loads first, then perform the connection and finally turn on the loads one by one. No matter the UPS is connected to the utility power or not, the output of the UPS may have electricity. The parts inside the unit may still have hazardous voltage after turning off the UPS. To make the UPS have no output, power off the UPS, and then disconnect the utility power supply.

- 10) Suggest charging the batteries for 8 hours before use. After connection, turn the bypass breaker in the “ON/OFF” position, the UPS will charge the batteries automatically. You can also use the UPS immediately without charging the batteries first, but the backup time may be less than the standard value.
- 11) If it is necessary to connect the inductance load such as a monitor or a laser printer to the UPS, the start-up power should be used for calculating the capacity of the UPS, as its start-up power consumption is too big when it is started.

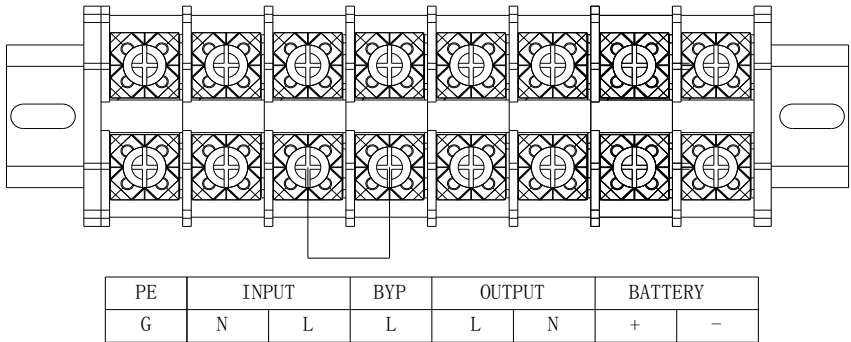

Input and output Terminal Block wiring diagram of 5K-10K(1phase)

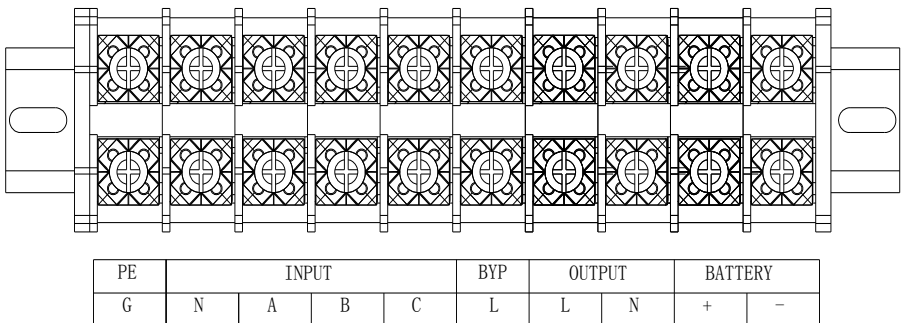

Input and output Terminal Block wiring diagram of three-phase 10-20kva

2.4 Operating procedure for connecting the long backup time model UPS with the external battery

-
1. The nominal DC voltage of external battery pack is 192/240VDC. Each battery pack consists of 16/ 20 pieces of 12V maintenance free batteries in series. To achieve longer back time, it is possible to connect multi-battery packs, but the principle of “same voltage, same type” should be strictly followed.2. The connector of the external battery cable is used to plug into the external battery socket of the UPS, the other end of the external battery cable is made of three open wires with ring terminals to connect with the external battery pack(s). The procedure of installing battery bank should be complied with strictly. Otherwise you may encounter the hazardous of electric shock.
 - 1) A DC breaker must be connected between the battery pack and the UPS. The capacity of breaker must be not less than the data specified in the general specification.
 - 2) Set the battery pack breaker in "OFF" position and connect the 16/20 pieces of batteries in series.
 - 3) You must connect the external battery cable to the battery first, if you connect the cable to the UPS first, you may encounter the hazardous of electric shock.
 - 3)3. To complete the connection by plugging the connector of the external battery cable into the external battery socket of the UPS. Do not attempt to connect any loads to the UPS now. You should connect the input power wire to the right position first. And then set the breaker of the battery pack in the ON position. After that set the bypass breaker in the ON position. The UPS begins to charge the battery packs at the time.

3. Operation and operating mode

3.1 Operation

3.1.1. Turn on the UPS with utility power supplied (in Line mode/AC mode)

- 1) After you make sure that the power supply connection is correct, set the bypass breaker and the input breaker in the “ON/OFF” position first. At this time the fan rotates and the UPS supplies power to the load via the bypass. The UPS operates in Bypass mode.
- 2) To power on the UPS by simply pressing the “ON/OFF” button continuously for more than 1 second.
- 3) When being powered on, the UPS will perform self-diagnosis, with the load/battery level LEDs turned on and then off one after another in ascending order. A few seconds later, the INV LED is turned on, the UPS is already running in Utility Power mode. If the utility power is abnormal, the UPS will operate in battery mode without output interruption of the UPS.

3.1.2. Turn on the UPS with no utility power supplied (in Battery mode)

-
- 4) Press the “ON/OFF” button continuously for more than 1 second to power on the UPS. For long back up time model (“L” model), please make sure that the battery breaker is in “ON/OFF” position.
 - 5) During the course of starting up, the UPS has the same action as if it is connected to utility power except that the utility power LED is not turned on and the battery LED is turned on instead.

3.1.3. Turn off the UPS with utility power supplied (in Line mode/AC mode)¹⁾

Press the “ON/OFF” button continuously for more than 1 second to turn off the inverter of the UPS immediately.

- 2) When being powered off, the UPS will perform self-diagnosis, the Load/Battery level LEDs will be turned on and then off one after another in ascending order, then the INV LED will be turned off and Bypass LED will be turned on. The UPS is working in Bypass mode.
- 3) Upon completion of the above to turn it off, output of electric current of the UPS is

still present. In order to cut off the output from the UPS, simply cut off the utility power supply and the UPS will perform self-diagnosis, finally not any display is shown on the display panel and no voltage output is available from the UPS output.

3.1.3. Turn off the UPS with no utility power supplied (in Battery mode)

- 1) Press the “ON/OFF” button continuously for more than 1 second to power off the UPS.
- 2) When being powered off, the UPS will perform self-diagnosis, the Load/Battery level LEDs will be turned on and then off one after another in ascending order. Finally not any display is shown on the display panel and no voltage is available from the UPS output.

Suggestions: Please turn off the connected loads before turning on the UPS and turn on the loads one by one after the UPS is working in INV mode. Turn off all of the connected loads before turning off the UPS.

3.2 Operating mode

3.2.1. Utility power mode

The display panel in utility power mode is shown in the following diagram. The utility power LED and the INV LED are turned on.

If the battery LED is turned on and the utility power LED flashes, it indicates the voltage or frequency of the utility power has exceeded the normal range, the UPS operates in battery mode.

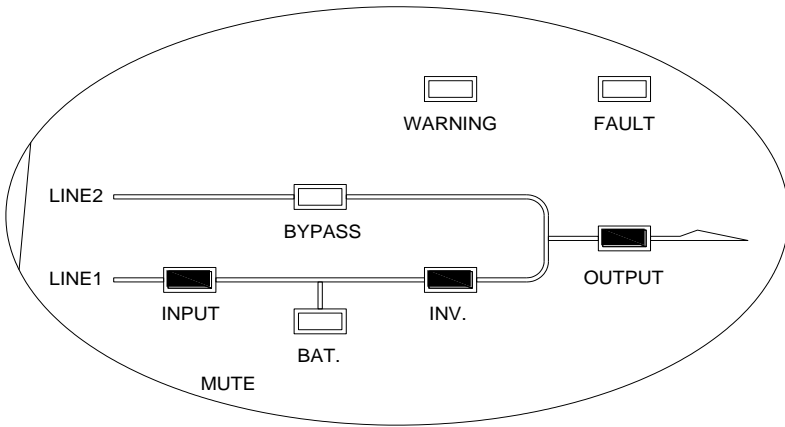

Fig 3-1 The utility power mode

2) If output overloaded, the warning LEDs will be turned on and alarm will keep twice every second. You should get rid of some unnecessary loads one by one to decrease the loads connected to the UPS less than 90% of its nominal power capacity.

- Note: Please follow the following steps to connect the generator: Activate the generator and wait until the operation is stable before supplying power of the generator to the UPS (be sure that the UPS is in idle mode). Then turn on the UPS according to the start-up procedure. After the UPS is turned on, then the loads can be connected to the UPS one by one.
- The power capacity of the AC generator should be at least twice of the UPS capacity.

3.2.2. Battery mode

The display panel in battery mode is shown in the following diagram Fig.3-2. The battery LED and the INV LED are turned on. When the UPS is running in battery mode, the buzzer beeps once every 4 seconds. If the “ESC” and “SCREEN” button on the front panel are pressed same time for more than 1 second again, the buzzer will stop beeping (in silence mode). If the Utility power is there but abnormal, the LED of it will flash.

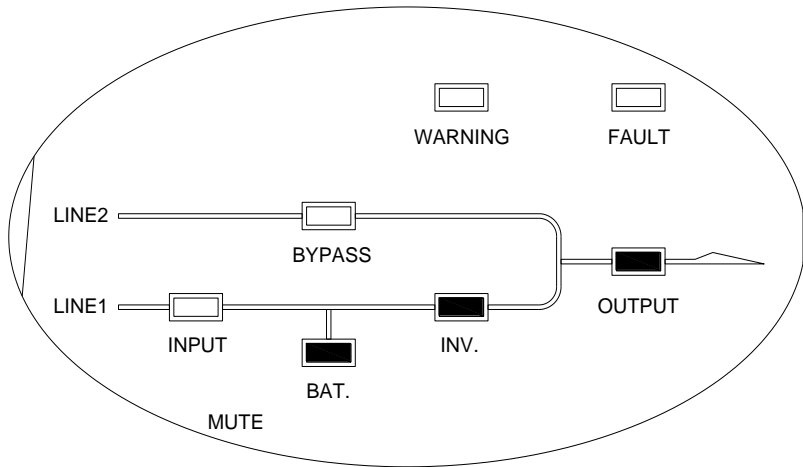

Fig 3-2 Battery mode diagram

2) When the battery capacity decreases, and the battery voltage descends to the alarm level, the buzzer will beep once every second to remind the users of insufficient battery capacity and the UPS is soon going to shut down automatically. Then the load operations should be carried out promptly and the loads should be eliminated one by one.

3.2.3. Bypass mode

The display panel in bypass mode is shown in the following diagram Fig.3-3. The utility power LED and the bypass LED are lit.

The utility power LED flashes, it shows that the voltage or frequency of the utility power has exceeded the normal range of the UPS.

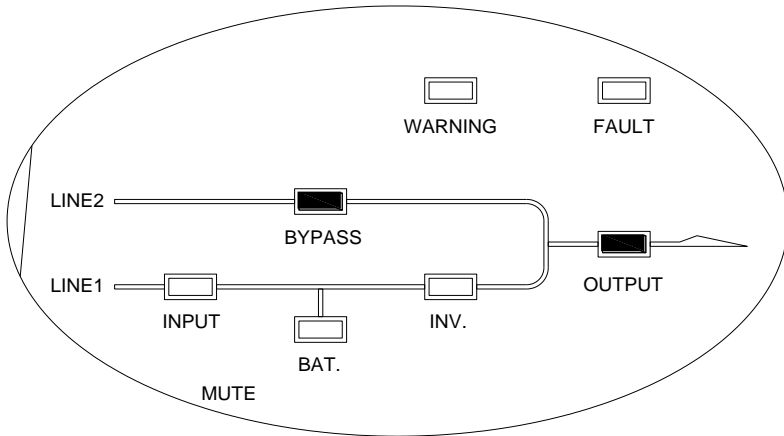

Fig 3-3 UPS bypass mode diagram

- 2) Other indications on the display panel are the same in utility mode.
- 3) The UPS does not have the backup function when it is in bypass mode. The power used by the load is supplied from the utility power via internal filter.

3.2.4. Abnormality mode

In case the fault LED is turned on when the UPS is in use, it shows that the UPS is operating in abnormal mode. Please refer to the troubleshooting in section 6 for detail.

3.2.5. Backup time for the standard model

The backup time of the long backup time model is dependent on the external battery pack capacity and the load level as well as other factors.

The backup time of standard model may vary from different models and load level. Please refer to the following.

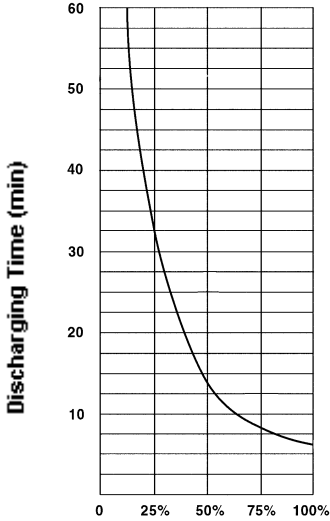

backup time of 6kVA

Load level

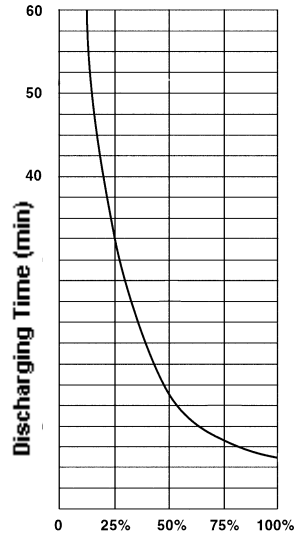

backup time of 10kVA

Load level

3.2.6. Communication Port

Intelligent slot

This series is equipped with an intelligent slot for Web power (optional accessory) or other optional card to achieve remote management of the UPS through internet / intranet. Please contact your local distributor for further information.

RS232 interface

1) The following are the descriptions and pin assignment of RS232 DB-9 port:

Baud rate: 2400bps

Data bit: 8 bit

Ending bit:1bit

Parity bit: None

DB-9 pin assignment:

Pin number	Function description	I/O
3	Rx	input
2	Tx	output
5	Ground	GND

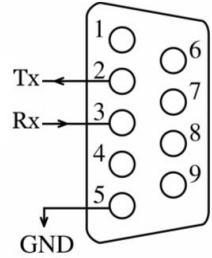

Optional AS400 interface

RS232 Interface

This optional AS400 card provides dry contact closure signal “OPEN” or “CLOSE”. Following are the pin assignment and the descriptions of AS400 card:

PIN1: UPS failure (normally open, active close)

PIN2: summary alarm PIN3: ground

PIN4: Remote shutdown

PIN5: Common

PIN6: Bypass active (relay close)

PIN7: Battery low

PIN8: UPS On (relay close)

PIN9: Utility Power failure (normally open, active close)

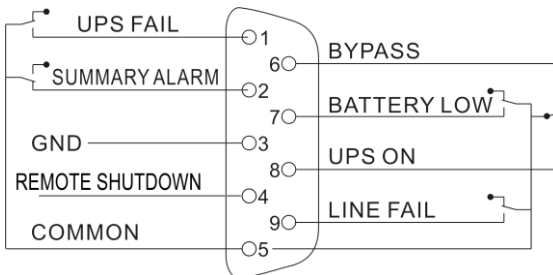

AS400 Interface

4. Battery Maintenance

- This series UPS only requires minimal maintenance. The battery used for standard models are value regulated sealed lead-acid maintenance free battery. These models require minimal repairs. The only requirement is to charge the UPS regularly in order to maximize the expected life of the battery. When being connected to the utility power, whether the UPS is turned on or not, the UPS keeps charging the batteries and also offers the protective function of overcharging .The UPS should be charged once every 4 to 6 months if it has not been used for a long time.
- In the regions of hot climates, the battery should be charged and discharged every 2 months. The standard charging time should be at least 12 hours.
- Under normal conditions, the battery life lasts 3 to 5 years. In case if the battery is found not in good condition, earlier replacement should be made. Battery replacement should be performed by qualified personnel.
- Replace batteries with the same number and same type of batteries.
- Do not replace the battery individually. All the batteries should be replaced at the same time following the instructions of the battery supplier.
- Normally, the batteries should be charged and discharged once every 4 to 6 months. Charging should begin after the UPS shuts down automatically and, the standard charging time for standard UPS at least 12 hours.

5. Notes for battery disposal and battery replacement

- 1) Before disposing of batteries, remove conductive jewelry such as necklace, wrist watches and rings.
- 2) If it is necessary to replace any connection cables, please purchase the original materials from the authorized distributors or service centers, so as to avoid overheat or spark resulting in fire due to insufficient capacity.
- 3) Do not dispose of batteries or battery packs in a fire, they may explode.
- 4) Do not open or mutilate batteries, released electrolyte is highly poisonous and harmful to the skin and eyes.
- 5) Do not short the positive and negative of the battery electrode, otherwise, it may result in electric shock or fire.

6) Make sure that there is no voltage before touching the batteries. The battery circuit is not isolated from the input potential circuit. There may be hazardous voltage between the battery terminals and the ground.

7) Even though the input breaker is disconnected, the components inside the UPS are still connected with the batteries, and there are potential hazardous voltages. Therefore, before any maintenance and repairs work is carried out, switch off the breaker of the battery pack or disconnect the jumper wire of connecting between the batteries.

8) Batteries contain hazardous voltage and current. Battery maintenance such as the battery replacement must be carried out by qualified personnel

6. Trouble shooting instructions

6.1 Warning code and Fault code

Warning code	Explanation	Solutions
N'O WARNING	UPS is working normally	
OVER LOAD	Overload	Reduce the load
BAT OPEN	Battery not connected	Connect battery and turn on the battery switch
OVER CHARGE	Battery is overcharged	
BAT DISCONNECT	Battery disconnected	Switch on the battery to make back up available
INV OVER TEMP	Inverter part temperature high	Cool it down
PFC OVER TEMP	PFC part temperature high	Cool it down
BYP LINE LOS S	Bypass not available	
LINE ORDER ERR	The 3phase A,B,C(R,S,T) not in right order	Check the phase order
BYPASS OVERLOAD	Bypass overloaded	Reduce the not critical load
Charger fail	Charger is fault	Check the charger
Fault code	Explanation	Solutions
NO FAULT	UPS is working normally	

BUS SOFT TIME EOUT'	BUS soft start time exceeded	Check PFC part
INVSOFT TIMEO UT'	INVERTER soft start time exceeded	Check the inverter part
INV RELAY FAI L	Inverter relay fault	Check the relay
INV SHORT	INVERTER short circuit	Check the inverter part
INV VOLT LOW	Inverter voltage low	Check the inverter
INV VOLT HIG H	Inverter voltage high	Check the inverter
INV OVER LOA D	Inverter voltage overload	Check the inverter
BUS VOLT OVE R	BUS over voltage	Check the bus
BUS VOLT UN DER	BUS under voltage	Check the bus
INV OVER TEM P	Inverter over temperature	Check the inverter
PFC OVER TE MP	PFC over temperature	Check the PFC
BYP SHORT	Bypass short circuit	Check the bypass
BYP OVER LOA D	Bypass overload	Check the bypass
BUS PEAK OVE R	Bus peak voltage over	Check the bus
BUSDISCHG FAI L	Bus discharging fault	Check the bus
BUS SHORT	Bus short circuit	Check the bus
PFC HARD FA IL	PFC hardware fault	Check the PFC
PFC CURR F AIL	PFC current fault	Check the PFC
INV CURR FA IL	Inverter current fault	Check the inverter
LINE ORDER E	3phase A,B,C(R,S,T) not in	Check the lines

RR	right order	
PN BUS FAUT	Positive and negative of Bus fault	Check the bus

6.2 Simple problem phenomena and solutions

Abnormal phenomenon	Fault diagnosis	Solutions
Alarming when connect the battery	Battery anode and cathode connection in reverse	Checking and reconnect
Fans stop running	Fans failed or board of fan damaged	Contact with technician for repair
UPS not start when turn on UPS	Switch failed	Check switch
	Power supply board failed	Contact with technician for repair
UPS no output when there is no mains	Battery switch didn't turn on or failed	Check switch
	Battery capacity is not enough to support power	Contact with technician for repair
UPS can not get normal communication	Communication software was set wrong or the communication cable is fault	Reset or replace the cable.
UPS don't start up in mains and UPS works normally in battery	Charging board has fault	Checking if input fuse of charging board are failed
Small charging current	Long backup charging board are failed	Checking if input fuse of charging board are failed

Buzzer alarming for a long time, FAULT light is bright	Heat sink of inverter is over temperature	Check if the heat dissipation is good or not
	UPS internal failed	Contact with technician

